



Automated targeting for inter-plant water integration

Irene Mei Leng Chew, Dominic Chwan Yee Foo*

Department of Chemical and Environmental Engineering, University of Nottingham Malaysia, Broga Road, 43500 Semenyih, Selangor, Malaysia

ARTICLE INFO

Article history:

Received 30 December 2008
Received in revised form 11 May 2009
Accepted 17 May 2009

Keywords:

Process integration
Mathematical optimisation
Pinch analysis
Targeting
Water minimisation

ABSTRACT

Apart from in-plant water recovery, inter-plant water integration (IPWI) offers another promising mean for the reduction of fresh water and wastewater flowrates for process plants. This paper extends the automated targeting technique that was developed for single water network into IPWI. This optimisation-based technique is based on the concept of pinch analysis, which enables the setting of various network targets prior to detailed design. The automated targeting technique is formulated as a linear programming model for which global optimum is guaranteed. The proposed technique is demonstrated using several industrial and literature examples.

© 2009 Elsevier B.V. All rights reserved.

1. Introduction

Based on the assessment on water resources, two third of the world population will face water stress by year 2025. It is estimated that by 2025, industrial water usage (which includes utility cooling and heating, processing, transportation, air conditioning, cleaning, etc.) will climb to 235 km³, accounted for about 11% of the total world water consumption [1,2]. Rapid industrial growth has contributed to serious water pollution in the world; hence, effective measures are needed to reduce industrial water withdrawals and discharges. Water recovery has hence been identified as a promising means in reducing the water stress faced by the worldwide community [3,4]. Concurrently, many systematic design methods for water recovery in the process plants based on *process integration* techniques have emerged in recent years. In particular, the insight-based technique of *pinch analysis* is perhaps the most established tool that attracts attention from both research community and industrial practitioners. It enables the setting of the minimum fresh water and wastewater flowrate targets for a water network, prior its detailed design. In the past decades, research in water network synthesis based on insight-based pinch analysis techniques has evolved from the targeting of minimum fresh water and wastewater flowrates [5–15] to the targeting of minimum regeneration [5,6,13,16–20] and wastewater treatment flowrates [12,21–24].

Apart from the insight-based approaches, various mathematical optimisation techniques were also developed, which may

be further classified into deterministic [25–29] and stochastic [30–34] approaches. These mathematical techniques complements the insight-based approach in dealing with more complex problems, e.g. multi-contaminant systems [25–27,31], complex operational constraints such as limited piping connections [32], forbidden/compulsory matches between the water-using processes [28,33], as well as process uncertainty [29,35]. More recently, Ng et al. [36,37] incorporated the pinch-based targeting concept in the mathematical formulation. This technique simplifies the two-step targeting procedure of the cascade analysis technique [8,13,20] while maintaining the advantage of setting network targets (e.g. minimum flowrates/cost) prior to detailed design.

Nevertheless, note that all the above-mentioned works were developed for a single water network, where water recovery is achieved by integrating water-using processes within the same network. A further mean to enhance water recovery is *inter-plant water integration* (IPWI), i.e., integration between different water networks. In this case, water-using processes may be grouped according to their geographical location or as different plants that are operated by different business entities. Hence, water *source(s)* in one network may be fed to satisfy *sink(s)* in another network.

The seminal work on IPWI was reported by Olesen and Polley [38] using the pinch-based load table technique that was developed for the *fixed load problems*. Spriggs et al. [39] later proposed the use of material recovery pinch diagram [7,10] for minimum flowrate targeting in IPWI for the *fixed flowrate problems*. However, the detailed targeting procedure was not reported until the work of Chew et al. [40]. Recently, Foo [15] extended the use of water cascade analysis which was developed for flowrate targeting in a single water network [8,13,14] to IPWI. However, the approach requires iterative steps in order to generate alternative water network schemes before the minimum water flowrates targets can be determined.

* Corresponding author. Tel.: +60 3 89248130; fax: +60 3 89248017.
E-mail addresses: Irene.Chew@nottingham.edu.my (I.M.L. Chew),
Dominic.Foo@nottingham.edu.my (D.C.Y. Foo).

Nomenclature

Sets

I	$\{i=1, 2, \dots, N_{\text{Sources}} \mid i \text{ is set of process sources}\}$
J	$\{j=1, 2, \dots, N_{\text{Sinks}} \mid j \text{ is set of process sinks}\}$
M	$\{m=0, 1, \dots, n \mid m \text{ is set of water quality levels}\}$
S	$\{s=0, 1, \dots, n \mid s \text{ is set of wastewater quality levels}\}$
K	$\{k \mid k \text{ is water networks}\}$
Q	$\{q \mid q \text{ is set of regeneration units}\}$
L	$\{l \mid l \text{ is set of treatment units}\}$

Variables

C_m	impurity concentration at level m in water reuse/recycle cascade
C_s	impurity concentration at level s in wastewater cascade
$F_{k',k}^{\text{IMP}}$	import flowrate from network k' to network k
$F_{k,k'}^{\text{EXP}}$	export flowrate from network k to network k'
$F_{\text{FW},k}^{\text{IPWI}}$	fresh water flowrate in network k after inter-plant water integration
$F_{\text{WW},k}^{\text{IPWI}}$	wastewater flowrate in network k after inter-plant water integration
F_D	total flowrate of wastewater discharge to the environment
$F_{k,q}^{\text{REG}}$	total regeneration flowrate for regeneration unit q in network k
$F_{i,k,q}^R$	regeneration flowrate sent from source i of network k to regeneration unit q
$F_{\text{TRI},l}$	wastewater flowrate sent from source i to treatment unit l
$F_{\text{WW},i}$	wastewater flowrate emitted from source i
F_{TI}	total treatment flowrate in treatment unit l
$m_{\text{REG}q}$	total impurity load removed by the regeneration unit q
$x_{k,k'}^{\text{EXP}}$	binary variable indicates the existence of export pipelines connecting between networks k and k'
$x_{k',k}^{\text{IMP}}$	binary variable indicates the existence of import pipelines connecting between networks k' and k
$\varepsilon_{m,k}$	residual impurity load at concentration level m in network k
$\beta_{m,k}$	residual impurity load at property level m in network k
$\delta_{m,k}$	net material flowrate at concentration level m in network k
Ψ_m	property operator at level m in water reuse/recycle cascade
ω_s	net wastewater flowrate at concentration level s in wastewater cascade
γ_s	residual impurity load at concentration level s in wastewater cascade

Parameters

AF	factor for annualising capital cost
a	fractional interest rate per year
D	distance between two plants
C_D	wastewater discharge limit
C_R	regeneration outlet quality
C_T	treatment outlet quality
C_{FW}	fresh water concentration
$C_{\text{SRI},k}$	limiting concentration of source i in network k
$C_{\text{SKJ},k}$	limiting concentration of sink j in network k

$F_{\text{SRI},k}$	limiting flowrate of source i in network k
$F_{\text{SKJ},k}$	limiting flowrate of sink j in network k
W_{COST}	fresh water unit cost
P_{COST}	annualised cross-plant piping cost
$R_{\text{COST}q}$	unit cost for regeneration unit q
$E_{\text{COST}l}$	unit cost for treatment unit l
AWH	annual working hour
LB_{cp}	lower bound for cross-plant flowrate
UB_{cp}	upper bound for cross-plant flowrate
y	number of years

This is cumbersome especially while dealing with problems with large number of water networks.

A few works on the use of mathematical optimisation techniques for IPWI were also reported. This includes the superstructural-based optimisation techniques by Lovelady et al. [41] for an integrated pulp and paper production case, multi-period problem by Liao et al. [42], eco-industrial park design with centralised water interception facility [43] as well as the recent developed work on direct and indirect IPWI schemes by Chew et al. [44].

In this paper, the automated targeting technique that was developed for single water network [36] is extended into IPWI scheme. Several industrial and literature examples involving concentration and property-based integration are used to illustrate the proposed technique. Depending on the problem, objective functions for some cases are set to determine the minimum fresh water and wastewater flowrate targets for the overall inter-plant as well as for the individual water networks; while others are set to minimise operation or total network costs. Note that these various targets are determined prior to the detailed design of the inter-plant water network.

2. Problem statement

Given a set of water networks k of the fixed flowrate type problem, with process sinks and sources are denoted as set j and i , respectively. Each process sink and source has its limiting water flowrate and quality that may be considered for water reuse/recycle. Water sources may also be sent for regeneration (for further reuse/recycle) or for treatment prior to environmental discharge. External fresh water source(s) is used to supplement additional water requirement of the process sink that is not satisfied by the process sources. An optimum inter-plant water network is to be synthesised to achieve the minimum flowrate/cost solution.

3. Automated targeting technique

The automated targeting technique was first developed by El-Halwagi and Manousiathakis [45] for the synthesis of mass exchange network. It was then extended to locate the minimum flowrate/cost targets for concentration [36] and property-based [37] resource conservation network. However, these earlier versions of the targeting techniques were developed for single water network. In this work, the automated targeting approach is extended into IPWI problem, in which sources/sinks of different water networks may be integrated. Note that the approach is first described for concentration-based IPWI problem. It will then be extended into property-based integration in the later section.

Fig. 1 shows a generic concentration cascade diagram for IPWI with direct reuse/recycle scheme. In developing the cascade diagram, a total of n sinks/sources concentration (C_m) for water network k are arranged in an ascending order, started from the

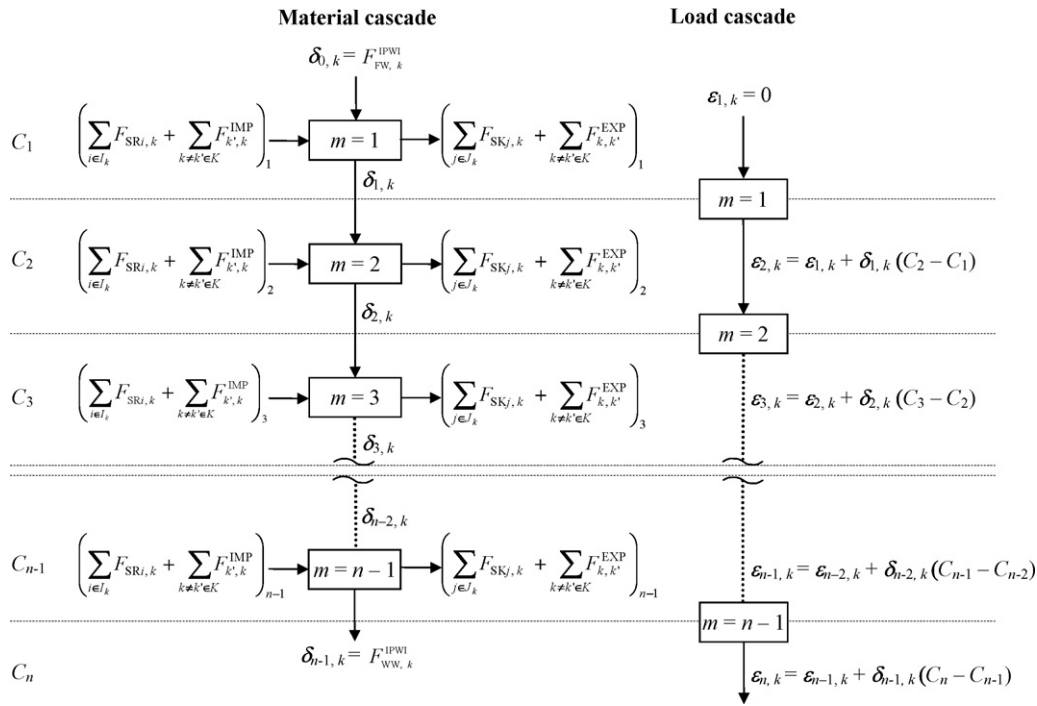

Fig. 1. Generic concentration cascade diagram for IPWI for direct reuse/recycle scheme.

lowest ($m=1$) to the highest level ($m=n$). Note that, a pure fresh water source with its concentration being the lowest level (among all sources and sinks) is always located at the first level. In contrast, when an impure fresh water source is present, it may be treated as a process source located at its respective concentration level [37]. Material and load cascades for each water network k are next described.

Material cascading is performed across all concentration intervals in a water network. At each concentration level m , the flowrate balance takes into account the sink and source flowrates of its individual network k and also the inter-plant flowrates to/from other network k' . In this case, the inter-plant flowrate that is received from network k' at the same concentration level is known as the *import flowrate* ($F_{k',k}^{IMP}$); while inter-plant flowrate which is sent to network k' is known as the *export flowrate* ($F_{k,k'}^{EXP}$). As shown in Fig. 1, for a given network k , the import flowrate (from network k'), $F_{k',k}^{IMP}$ is treated as a source, and is added along with other source flowrate of the individual network ($F_{SRi,k}$) on the left of the material cascade. On the other hand, the export flowrate (to be sent to network k'), $F_{k,k'}^{EXP}$ is treated as a sink, and hence is added on the right of the material cascade along with other sink flowrates ($F_{SKj,k}$). It is worth noting that the automated targeting technique considers all possibility of source-sink mixing across all individual networks, as all imported sources are used to satisfy the sinks in the local network.

Eq. (1) summarises that the *net material flowrate* from level m for network k ($\delta_{m,k}$), is given by the summation of the net material flowrate cascaded from the earlier concentration level ($\delta_{m-1,k}$) with the net flowrates at concentration level m . Note that, the net material flowrate ($\delta_{m,k}$) can either take positive or negative value, with positive value indicates material that flows from the lower into higher concentration level, and vice-versa [36,37]. Note also that, fresh water flowrate ($F_{FW,k}^{IPWI}$) is supplied to the individual water network k in the first concentration level (i.e. $\delta_{0,k} = F_{FW,k}^{IPWI}$), when the fresh water supply is of the highest quality among all water sinks and sources (impure fresh water is located in its respective level m). On the other hand, the wastewater flowrate ($F_{WW,k}^{IPWI}$) is discharged

from the last level of the material cascade (see Fig. 1).

$$\delta_{m,k} = \delta_{m-1,k} + \left(\sum_{i \in I} F_{SRi,k} + \sum_{k',k' \in K} F_{k',k}^{IMP} \right)_m - \left(\sum_{j \in J} F_{SKj,k} + \sum_{k,k' \in K} F_{k,k'}^{EXP} \right)_m \quad k \neq k', \forall k \in K, \forall m \in M \quad (1)$$

Next, the *load cascading* for each network k is carried out. First, the impurity load in each concentration interval is determined. This is given by the product of the net material flowrate at level $m-1$ ($\delta_{m-1,k}$) and the concentration difference of the interval, i.e. $C_m - C_{m-1}$. Next, the residual load at each level ($\epsilon_{m,k}$) is calculated. As shown in Fig. 1, residual load is determined by summing the contaminant load in the concentration intervals with the residual contaminant load from the earlier level ($\epsilon_{m-1,k}$), as given by Eq. (2).

$$\epsilon_{m,k} = \epsilon_{m-1,k} + \delta_{m-1,k}(C_m - C_{m-1}) \quad \forall m \in M, \forall k \in K \quad (2)$$

An additional constraint is included in the automated targeting model (Eq. (3)) to ensure that the net contaminant load of each level m to bear a zero or positive value. Note also that, a pinch point that represents the overall bottleneck for a water network is located where a zero residue contaminant load is observed.

$$\epsilon_{m,k} \geq 0 \quad \forall m \in M, \forall k \in K \quad (3)$$

Finally, note that the above automated targeting model is linear in nature, for which global optimum is guaranteed. The approach will now be demonstrated using three examples. The first two examples demonstrate the application of the automated targeting technique for conventional concentration-based IPWI problems, while the third example extends the application into the property-based IPWI case.

Table 1
Limiting water data for Example 1 (integrated iron and steel mill).

Sinks SK _j	Unit	Sink flowrate F _{SKj} (million m ³ /y)	Concentration C _{SKj} (mg/L)	Sources SR _i	Source flowrate F _{SRi} (million m ³ /y)	Concentration C _{SRi} (mg/L)
Network A—raw material storage yard						
1	Wet cyclone scrubber	10.00	20	1	9.00	23
Network B—cooking plant						
2	Cook quench tower	12.29	20	2	11.92	23
3	COG scrubber	12.29	19	3	11.92	23
Network C—steel making plant						
4	Hot air scrubber	59.60	75	4	57.81	100
5	Slag processing	39.73	80	5	38.54	100
Network D—casting/rolling mills						
6	Mold cooling	198.66	20	6	192.70	20.5
7	Slab cooling	198.66	20	7	192.70	20.5
8	Fume absorber	44.73	20	8	43.39	21
9	Rinsing	178.92	20	9	173.55	20.5
10	Acid pickling	44.73	100	10	43.39	400
Network E—indirect cooling						
11	Indirect cooling	468.55	20	11	459.18	20.2
$\sum_j F_{SKj}$		1268.16	$\sum_i F_{SRi}$		1234.10	

Bold values signify summation of the sink/source flowrates.

4. Example 1—integrated iron and steel mill

An integrated iron and steel mill that consists of multiple water networks is used to illustrate the proposed automated targeting approach. Table 1 shows the limiting water data for this example. As shown, there are five water networks in the mill, which are segregated based on the different processing area of the plant, i.e. raw material storage yard, cooking plant, steel making plant, casting/rolling mills and indirect cooling. The main contaminant in concern for water recovery is the ionic chloride content in the water. In this case the fresh water supply contains a Cl⁻ level (C_{FW}) of 15 mg/L. Before conducting IPWI, the overall minimum fresh water and wastewater flowrates across all individual networks for the reuse/recycle case is determined as 116.32 million m³/y and 82.25 million m³/y, respectively.

In order to synthesise an optimum inter-plant water network, a two-step optimisation approach is adopted here. First, objective function in Eq. (4) is used to minimise the overall fresh water requirement across all individual networks:

$$\min \sum_{k \in K} F_{FW,k}^{IPWI} \quad (4)$$

In the second step, objective function in Eq. (5) is used to minimise the cross-plant flowrate subject to the minimum fresh water target obtained in the first step (Eq. (4)). The second optimisation step is important as minimum cross-plant flowrate leads to lower piping cost.

$$\min \sum_{k \in K} F_{k,k'}^{EXP} \quad (5)$$

A commercial optimisation software LINGO v10 is used to solve the model. Solving the objective function in Eq. (4) for the first optimisation step subjects to the constraints in Eqs. (1–3) yields the minimum overall network fresh water and wastewater flowrates of 81.59 and 47.54 million m³/y, respectively. The minimum fresh water flowrate obtained in the first stage is then added as a new constraint in step 2. Next, the objective function in Eq. (5) is solved subjects to the constraints in Eqs. (1–3), along with the new fresh water flowrate constraint, yields the minimum total cross-plant flowrates of 77.48 million m³/y. Cascade diagrams for all individual networks are shown in Fig. 2. As shown, the sink (F_{SKj}), source (F_{SRi}), import (F_{k,k'}^{IMP}), and export (F_{k,k'}^{EXP}) flowrates for each network

are labelled at their respective concentration level *m*, with the minimum fresh water and wastewater flowrates at the highest and lowest intervals respectively. Integration for Network A is briefly explained (see Fig. 2a). As shown, Network A has a sink at 20 ppm (F_{SK1} = 10 t/h) and a source at 23 ppm (F_{SR1} = 9 t/h). Meanwhile, two import flowrates are observed at 20.2 ppm (F_{E,A}^{IMP} = 8.66 t/h) and 21 ppm (F_{D,A}^{IMP} = 0.83 t/h), which were sent from Networks E and D, respectively. In contrast, only one export flowrate to Network C is observed at 23 ppm (F_{A,C}^{EXP} = 9 t/h). Note that there are several 'inactive' concentration levels in which neither individual network source/sink nor inter-plant flowrates are found, e.g. 19, 20.5, 75, 80, 100 and 400 ppm. Hence, these levels have been excluded in the cascade diagrams for simplification.

Fig. 3 shows one of the possible network designs for Example 1 that achieves the targeted total minimum flowrates.

5. Waste interception

Waste interception is commonly used to improve the quality of water sources. The intercepted water can either be further reused/recycled in the water network (often known as *regeneration*) or sent for environmental discharge. In the former case, the intercepted water source(s) can either be consumed within the individual network, or be integrated with water sinks in another network via IPWI. Interception units are commonly rated as the *fixed outlet quality* and *fixed removal ratio* types.

The incorporation of various types of interception units in the automated targeting technique was reported recently [47], however, for single water network. The approach will now be extended for IPWI. For simplicity, only the fixed outlet quality type interception unit will be analysed. The same approach works equally well for a fixed removal ratio type interception unit, as demonstrated elsewhere [47].

When interception unit is considered, modification is needed on the automated targeting model. In essence, for each concentration level *m* where source *i* exists, potential interception flowrate (F_{i,k,q}^R) is added as a new sink in the material cascade for each network *k*, as shown in Fig. 4. The intercepted flowrate from interceptor *q* (F_{k,q}^{REG}) is then added as a source at the outlet purity level for each network *k*. This will enable the intercepted water for further reuse/recycle in the water network [46]. Eq. (6) states the flowrate balance for interception unit *q*. In addition, the source flowrate, F_{SRi} is set as

Table 2
Limiting water data for Example 2 (Eco-industrial park).

Sinks (SKj)	Sink flowrate, F_{SKj} (t/h)	Concentration, C_{SKj} (ppm)	Sources (SR _i)	Source flowrate, F_{SRi} (t/h)	Concentration, C_{SRi} (ppm)
Network A					
1	3500	500	1	3000	50
Network B					
2	1000	760	2	1000	400
Network C					
3	2500	40	–	–	–
Network D					
–	–	–	3	3000	1100
Network E					
4	2000	225	4	1300	1600
–	–	–	5	200	1800
$\sum_j F_{SKj}$	9000		$\sum_i F_{SRi}$	8500	

Bold values signify summation of the sink/source flowrates.

C_m (mg/L)	$F_{B,A}^{IMP}$	$F_{C,A}^{IMP}$	$F_{D,A}^{IMP}$	$F_{E,A}^{IMP}$	F_{SRi}	δ_m	F_{SKj}	$F_{A,B}^{EXP}$	$F_{A,C}^{EXP}$	$F_{A,D}^{EXP}$	$F_{A,E}^{EXP}$	ϵ_m
20						$F_{FW,A}^{IPWI} = 0.51$	10.00					2.56
						↓						↓
20.2	0	0	0	8.66		-9.49						0.67
						↓						↓
21	0	0	0.83	0		-0.83						0
						↓						↓
23					9.00	0		0	9.00	0	0	0
						↓						↓
						$F_{WW,A}^{IPWI} = 0.00$						↓
1000000												0

(a) Network A – Raw material storage

C_m (mg/L)	$F_{A,B}^{IMP}$	$F_{C,B}^{IMP}$	$F_{D,B}^{IMP}$	$F_{E,B}^{IMP}$	F_{SRi}	δ_m	F_{SKj}	$F_{B,A}^{EXP}$	$F_{B,C}^{EXP}$	$F_{B,D}^{EXP}$	$F_{B,E}^{EXP}$	ϵ_m
19						$F_{FW,B}^{IPWI} = 6.15$	12.29					24.58
						↓						↓
20						-6.14	12.29					18.44
						↓						↓
21	0	0	18.43	0		-18.43						0
						↓						↓
23					23.84	0		0	20.67	3.17	0	0
						↓						↓
						$F_{WW,B}^{IPWI} = 0.00$						↓
1000000												0

(b) Network B – Cooking plant

C_m (mg/L)	$F_{A,C}^{IMP}$	$F_{B,C}^{IMP}$	$F_{D,C}^{IMP}$	$F_{E,C}^{IMP}$	F_{SRi}	δ_m	F_{SKj}	$F_{C,A}^{EXP}$	$F_{C,B}^{EXP}$	$F_{C,D}^{EXP}$	$F_{C,E}^{EXP}$	ϵ_m
23	9.00	20.67	0	0		$F_{FW,C}^{IPWI} = 0.00$						0
						↓						↓
75						29.67	59.60					1542.85
						↓						↓
80						-29.93	39.73					1393.20
						↓						↓
100					96.35	-69.66		0	0	16.72	0	0
						↓						↓
						$F_{WW,C}^{IPWI} = 9.97$						↓
1000000												9.97E+06

(c) Network C – Steel making plant

Fig. 2. Cascade diagram for Example 1—integrated iron and steel mill (flowrates is given in million m³/y).

C_m (mg/L)	F_{AD}^{IMP}	F_{BD}^{IMP}	F_{CD}^{IMP}	F_{ED}^{IMP}	F_{SRi}	δ_m	F_{SKj}	F_{DA}^{EXP}	F_{DB}^{EXP}	F_{DC}^{EXP}	F_{DE}^{EXP}	ϵ_m
							$F_{FW,D}^{IPWI} = 56.92$					
20						↓	621.0					284.58
						-564.05						↓
20.5					558.95	↓						2.55
						-5.10						↓
21					43.39	↓		0.83	18.43	0	0	0
						19.02						↓
23	0	3.17	0	0		↓					38.04	
						22.19						↓
100	0	0	16.72	0		↓	44.73					1746.77
						-5.82						↓
400					43.39	↓		0	0	0.63	0	0
							$F_{WW,D}^{IPWI} = 37.57$					↓
1000000												3.76E+07

(d) Network D – Casting/rolling mills

C_m (mg/L)	F_{AE}^{IMP}	F_{BE}^{IMP}	F_{CE}^{IMP}	F_{DE}^{IMP}	F_{SRi}	δ_m	F_{SKj}	F_{EA}^{EXP}	F_{EB}^{EXP}	F_{EC}^{EXP}	F_{ED}^{EXP}	ϵ_m
							$F_{FW,E}^{IPWI} = 18.02$					
20						↓	468.55					90.11
						-450.53						↓
20.2					459.18	↓		8.66	0	0	0	0
							$F_{WW,E}^{IPWI} = 0.00$					↓
1000000												0

(e) Network E – Indirect cooling

Fig. 2. (Continued).

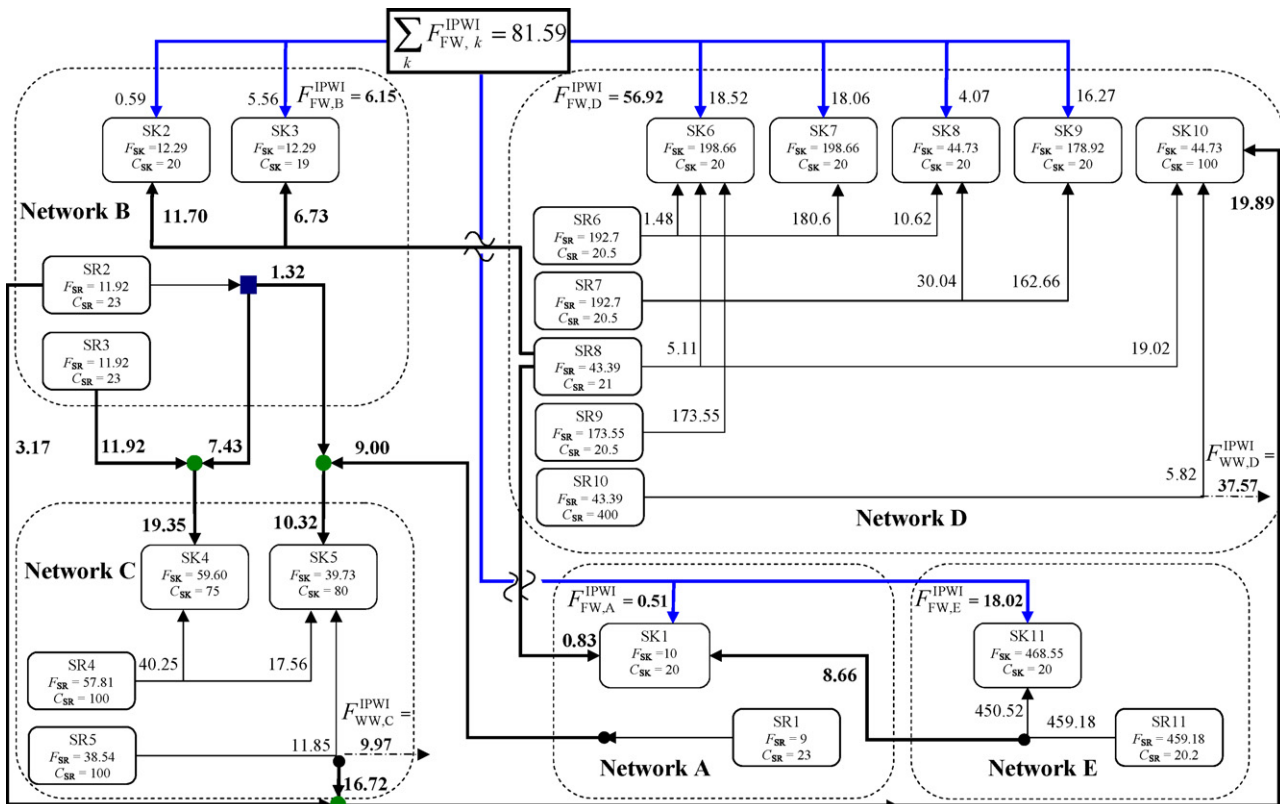

Fig. 3. Inter-plant water network design for Example 1 (flowrate is given in million m³/y and concentration in mg/L).

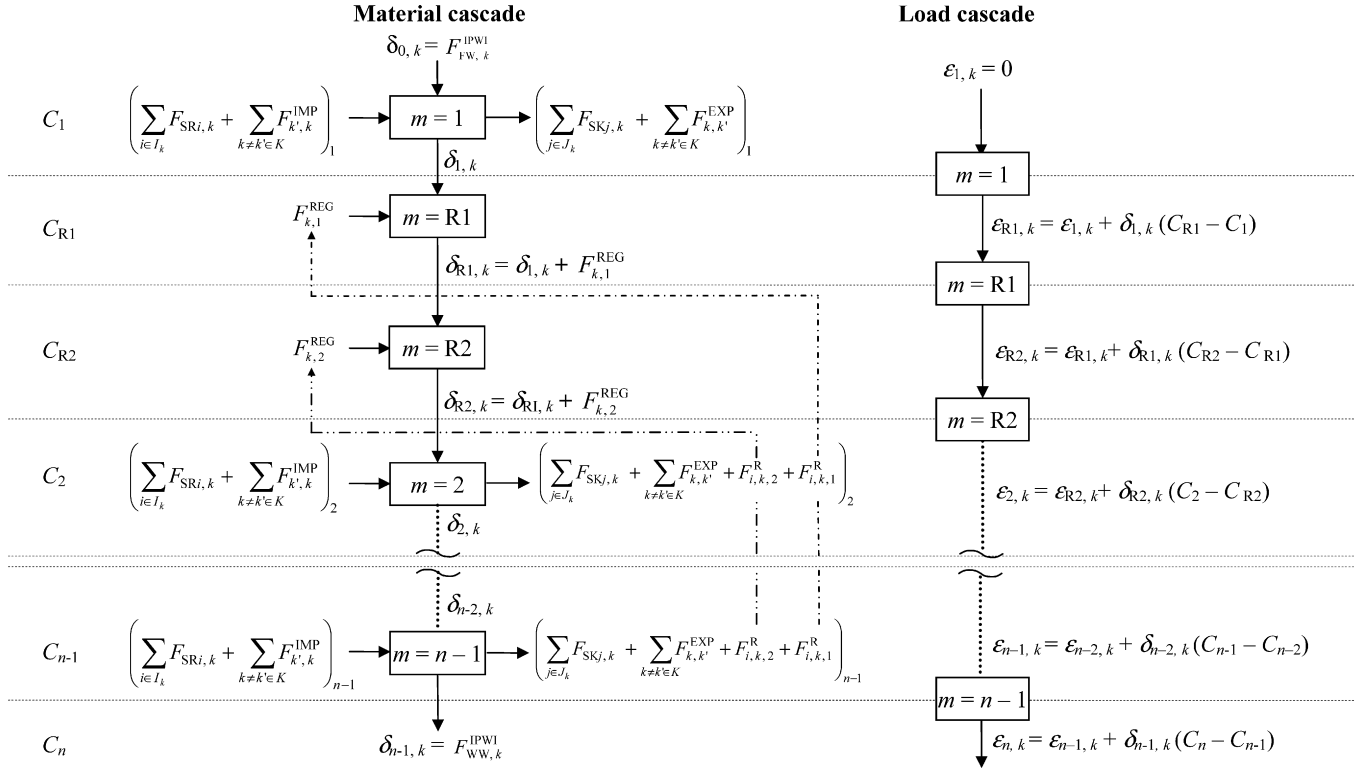

Fig. 4. Generic concentration cascade diagram for IPWI with fixed C_R type regeneration unit.

the upper bound of the interception flowrate, as given in Eq. (7). Fig. 4 shows a generic concentration cascade diagram when two interception units (R1 and R2) of the fixed outlet quality type are used. As shown, two new outlet quality levels (C_{R1} and C_{R2}) are added in the cascade to enable water interception to take place. Note that the number of new level(s) is dependent on the outlet quality of the interception units.

$$\sum_{q \in Q} F_{k,q}^{\text{REG}} = \sum_{i \in I_k} \sum_{q \in Q} F_{i,k,q}^R \quad k \neq k', \forall k \in K \quad (6)$$

$$\sum_{q \in Q} F_{i,k,q}^R \leq F_{\text{SR}i} \quad \forall i \in I_k \quad (7)$$

A literature example is used to illustrate this concept.

6. Example 2—IPWI in an eco-industrial park

Table 2 shows the limiting data for five water networks in an eco-industrial park (EIP) [43], where resources are shared and by-products streams are exchanged among industrial sites for sustainable development goal and improved environmental quality. As shown in Table 2, some networks (Networks A, B and E) contain both water sinks and sources while others (Networks C and D) have only source or sink. An opportunity of water saving exists and it can be materialised through IPWI. Apart from maximising water saving through direct reuse/recycle, a centralised regeneration unit with fixed outlet concentration is utilised to purify the water sources for further water recovery.

This model is optimised by minimising the annual water costs, i.e. fresh water and regeneration costs as stated at Eq. (8), where W_{COST} and $R_{\text{COST}q}$ are fresh water and regeneration unit cost, respectively; and AWH denotes the annual operating hour of the network. The regeneration cost is determined based on the total impurity load removed by the regeneration unit q in the overall inter-plant

network, as given in Eq. (9).

$$\min \left(\sum_{k \in K} F_{\text{FW},k}^{\text{IPWI}} W_{\text{COST}} + \sum_{q \in Q} m_{\text{REG}q} R_{\text{COST}q} \right) \text{AWH} \quad (8)$$

$$\sum_{q \in Q} m_{\text{REG}q} = \sum_{i \in I_k} \sum_{k \in K} \sum_{q \in Q} F_{i,k,q}^R (C_i - C_R) \quad (9)$$

For comparison with the original work [43], a single regeneration unit with $C_R = 500$ ppm is assumed here. Note that, since the regeneration unit has a C_R value of 500 ppm, only three sources with concentration higher than 500 ppm (i.e. SR3, SR4 and SR5) are considered for regeneration. It is assumed that the fresh water source is free of contaminant, i.e. $C_{\text{FW}} = 0$ ppm. The unit cost of fresh and regenerated water is taken as \$0.6/t and \$0.05/kg of impurity load removed. Note that the treatment cost of wastewater is not reported in the original source [43], however it can be added easily in Eq. (9). It is further assumed that the industrial complex is operated for 8760 h per year.

Solving the objective function in Eq. (8) subjects to the constraints in Eqs. (1–3), (6 and 7) and (9), the minimum cost solution of \$4,042,740/y is generated, identical to the reported result by Lovelady and El-Halwagi [43]. The resulted minimum cost solution of \$4,042,740/y is then added as a new constraint when solving the objective function in Eq. (5), subjects to the constraints in Eqs. (1–3), (6 and 7), and (9), to yield the minimum total cross-plant flowrates of 4200 t/h. Fig. 5 shows the cascade diagram for each network. As shown, a total regeneration flowrate of 4300 t/h is drawn from Networks D and E. The regenerated water with an outlet concentration of 500 ppm is then sent to Networks A and B for further reuse. Note that only Network C uses fresh water, similar to the result obtained in the earlier work [43]. Fig. 6 shows the inter-plant water network for Example 2 that achieves the targeted minimum water cost and flowrates. Note that this network is essentially a hybrid model of

C_m (ppm)	$F_{B,A}^{IMP}$	$F_{C,A}^{IMP}$	$F_{D,A}^{IMP}$	$F_{E,A}^{IMP}$	F_{SRi}	δ_m	F_{SKj}	$F_{A,B}^{EXP}$	$F_{A,C}^{EXP}$	$F_{A,D}^{EXP}$	$F_{A,E}^{EXP}$	ϵ_m
50	[]				3000	$F_{FW,A}^{IPWI} = 0$		0	2000	0	1000	0
500	[]				$F^{REG} = 3500$	0	3500	[]				0
1000000	[]					$F_{WW,A}^{IPWI} = 0$		[]				0

(a) Network A

C_m (ppm)	$F_{A,B}^{IMP}$	$F_{C,B}^{IMP}$	$F_{D,B}^{IMP}$	$F_{E,B}^{IMP}$	F_{SRi}	δ_m	F_{SKj}	$F_{B,A}^{EXP}$	$F_{B,C}^{EXP}$	$F_{B,D}^{EXP}$	$F_{B,E}^{EXP}$	ϵ_m
400	[]				1000	$F_{FW,B}^{IPWI} = 0$		0	0	0	1000	0
500	[]				$F^{REG} = 800$	0		[]				0
760	[]					800	1000	[]				208000
1800	0	0	0	200		-200		[]				0
1000000	[]					$F_{WW,B}^{IPWI} = 0$		[]				0

(b) Network B

C_m (ppm)	$F_{A,C}^{IMP}$	$F_{B,C}^{IMP}$	$F_{D,C}^{IMP}$	$F_{E,C}^{IMP}$	F_{SRi}	δ_m	F_{SKj}	$F_{C,A}^{EXP}$	$F_{C,B}^{EXP}$	$F_{C,D}^{EXP}$	$F_{C,E}^{EXP}$	ϵ_m
0	[]					$F_{FW,C}^{IPWI} = 500$		[]				0
40	[]					500	2500	[]				20000
50	2000	0	0	0		-2000		[]				0
1000000	[]					$F_{WW,C}^{IPWI} = 0$		[]				0

(c) Network C

C_m (ppm)	$F_{A,D}^{IMP}$	$F_{B,D}^{IMP}$	$F_{C,D}^{IMP}$	$F_{E,D}^{IMP}$	F_{SRi}	δ_m	F_{SKj}	$F_{D,A}^{EXP}$	$F_{D,B}^{EXP}$	$F_{D,C}^{EXP}$	$F_{D,E}^{EXP}$	ϵ_m	
1100	[]				3000	$F_{FW,D}^{IPWI} = 0$		$F^R = 3000$	[]				0
1000000	[]					$F_{WW,D}^{IPWI} = 0$		[]				0	

(d) Network D

C_m (ppm)	$F_{A,E}^{IMP}$	$F_{B,E}^{IMP}$	$F_{C,E}^{IMP}$	$F_{D,E}^{IMP}$	F_{SRi}	δ_m	F_{SKj}	$F_{E,A}^{EXP}$	$F_{E,B}^{EXP}$	$F_{E,C}^{EXP}$	$F_{E,D}^{EXP}$	ϵ_m	
50	1000	0	0	0		$F_{FW,E}^{IPWI} = 0$		[]				0	
225	[]					1000	2000	[]				175000	
400	0	1000	0	0		-1000		[]				0	
1600	[]				1300	0		$F^R = 1300$	[]				0
1800	[]				200	0		0	200	0	0	0	
1000000	[]					$F_{WW,E}^{IPWI} = 0$		[]				0	

(e) Network E

Fig. 5. Cascade diagram for Example 2 (flowrate is given in t/h).

Table 3
Limiting water data for Example 3 (wafer fabrication plants).

Plant	Process	Flowrate (t/h)	Resistivity, R ($M\Omega$)		Operator, Ψ ($M\Omega^{-1}$)		Heavy metal concentration (ppm)
Plant A	Sink						
	Wet (SK1)	500.00	7.0	18.0	0.1429	0.0556	–
	Litography (SK2)	450.00	8.0	15.0	0.1250	0.0667	–
	CMP (SK3)	700.00	10.0	18.0	0.1000	0.0556	–
	Etc (SK4)	350.00	5.0	12.0	0.2000	0.0833	–
	Source						
	Wet I (SR1) (WW1)	250.00	1.0		1.0000		5.0
	Wet II (SR2) (WW2)	200.00	2.0		0.5000		4.5
	Litography (SR3) (WW3)	350.00	3.0		0.3333		5.0
	CMP I (SR4) (WW4)	300.00	0.1		10.000		10.0
	CMP II (SR5) (WW5)	200.00	2.0		0.5000		4.5
	Etc (SR6) (WW6)	280.00	0.5		2.0000		5.0
	Plant B	Sink					
Wafer Fab (SK5)		182.00	16.0	20.0	0.0625	0.0500	–
CMP (SK6)		159.00	10.0	18.0	0.1	0.0556	–
Source							
50% spent (SR7) (WW7)		227.12	8.0		0.1250		5.0
100% spent (SR8) (WW8)		227.12	2.0		0.5000		11.0
Ultra pure water (UPW)	?	18.0		0.0556		–	

the direct and indirect integration schemes presented by Chew et al. [44].

In the following section, the automated targeting technique is extended into the property-based IPWI problem.

7. Property-based inter-plant water integration

Note that previous examples reported works that are both *chemo-centric*, where the characterisation of the process streams and constraints are described in terms of impurity concentration. Shelley and El-Halwagi [48] reported that there are many design problems that are driven by properties or functionality of the process streams (e.g. pH, conductivity, turbidity, toxicity, etc.) instead of their chemical constituent. Besides, defining the properties of a process stream with complex mixtures eliminates the need of tracking every single chemical component present in the stream. To address design problems that are governed by functionalities and properties, the framework of *property integration* was proposed, which is defined as “a functionality-based, holistic approach to the

allocation and manipulation of streams and processing units, which is based on the tracking, adjustment, assignment, and matching of functionalities throughout the process” [49]. Several important works on property integration have been reported. These include the various graphical, algebraic and optimisation techniques developed for continuous [37,49–52] and batch processes [53,54].

In order to track the individual property, a general mixing rule is often used to define the mixing patterns among them. One such form of mixing rule is given by the following expression [48]:

$$\psi(\bar{p}) = \sum_i x_i \psi(p_i) \quad (10)$$

where $\psi(p_i)$ and $\psi(\bar{p})$ are the linearised operators on source i and the mixture property, respectively, and x_i is the fractional contribution of source i in the total mixture flowrate. In the following section, the automated targeting technique is extended into a property-based IPWI problem. Example 3 that involves water integration between two wafer fabrication plants is used as an illustrative example.

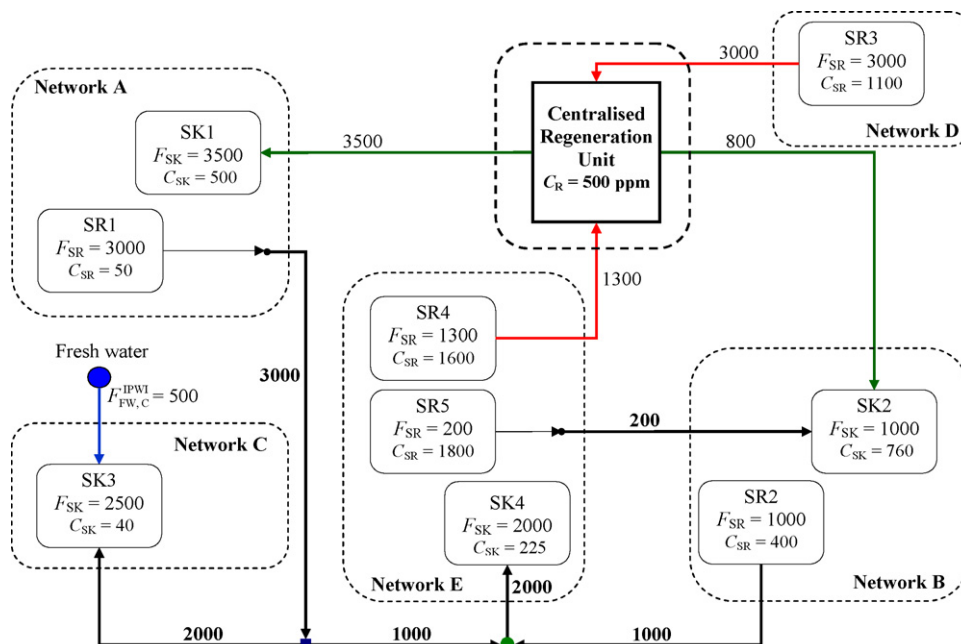

Fig. 6. Inter-plant water network design with regeneration unit for Example 2 (flowrate given in t/h and concentration in ppm).

8. Example 3 – IPWI for wafer fabrication plants

Example 3 illustrates the use of the automated targeting technique for IPWI that involves two wafer fabrication plants. An overall framework of total water network [23,24,46,55] is adopted, where analysis is conducted for all individual elements of a water network simultaneously, i.e. direct reuse/recycle, regeneration (with reuse/recycle) and wastewater treatment. Limiting data for water sinks and sources are taken from literature [37,56], and given in Table 3. As shown, both wafer fabrication plants possess similar process stream characteristics, i.e. resistivity and heavy metal content. Resistivity is taken as the main characteristic in evaluating water reuse/recycle opportunity between both plants; while heavy metal content is the limitation for final wastewater discharge. Ultra pure water (UPW, 18 MΩ, unit cost = \$2/t) is used when process water sources are insufficient. The mixing rule for resistivity, R is given as follows [57]:

$$\frac{1}{\bar{R}} = \sum_i \frac{x_i}{R_i} \quad (11)$$

Before implementing IPWI, the total minimum fresh water and wastewater flowrates for two individual networks in reuse/recycle case are determined as 1736.85 and 1430.41 t/h, respectively. The objective function of the IPWI problem is to minimise the total annualised cost for the overall network, which includes fresh water, regeneration, wastewater treatment and cross-plant piping costs (annual operating hours are taken as 8760 h):

$$\min \left(\sum_{k \in K} F_{FW,k}^{IPWI} W_{COST} + \sum_{k \in K} \sum_{q \in Q} F_{k,q}^{REG} R_{COSTq} + \sum_{l \in L} F_{Tl} E_{COSTl} \right) AWH + P_{COST} \quad (12)$$

where $F_{q,k}^{REG}$ and F_{Tl} are the regeneration and wastewater treatment flowrates in regeneration unit q and treatment unit l , respectively, each with an individual unit costs of R_{COSTq} and T_{COSTl} (include annualised capital cost). Cross-plant piping cost, P_{COST} is adopted from Kim and Smith [58] and is given in Eq. (13). The piping cost considers the use of carbon steel pipes, with the cost parameters of $u_I = 7200$ and $u_{II} = 250$ (converted to USD from the original value in [58]); CE plant index = 318.3). It is further assumed that the stream flowrate velocity, $v = 1 \text{ m s}^{-1}$ and water density, $\rho = 1000 \text{ kg m}^{-3}$ throughout this study. A distance (D) of 100 m is assumed between the two plants. Piping cost within the individual network is assumed negligible, as it is relatively much smaller as compared to the cross-plant pipeline.

$$P_{COST} = D \left[\left(u_I \frac{F_{k,k'}^{EXP}}{3600\rho v} + u_{II} x_{k,k'}^{EXP} \right) + \left(u_I \frac{F_{k',k}^{IMP}}{3600\rho v} + u_{II} x_{k',k}^{IMP} \right) \right] AF \quad (13)$$

$k \neq k'$

Binary variables $x_{k,k'}^{EXP}$ and $x_{k',k}^{IMP}$ in Eq. (13) indicate the existence of export and import piping, respectively. Eqs. (14) and (15) give the upper (UB_{CP}) and lower (LB_{CP}) bounds for the cross-plant flowrates, which are assumed as 0 and 350 t/h, respectively, in this case. However, note that the binary variables in Eqs. (14) and (15) lead to an MILP model.

$$LB_{CP} x_{k,k'}^{EXP} \leq F_{k,k'}^{EXP} \leq UB_{CP} x_{k,k'}^{EXP} \quad k \neq k' \quad (14)$$

$$LB_{CP} x_{k',k}^{IMP} \leq F_{k',k}^{IMP} \leq UB_{CP} x_{k',k}^{IMP} \quad k \neq k' \quad (15)$$

A factor (AF) is used to annualise the piping capital cost in Eq. (13), defined as [59]:

$$AF = \frac{a(1+a)^y}{(1+a)^y - 1} \quad (16)$$

where a = fractional interest rate per year, y = number of years. For this example, it is assumed that the cross-plant piping capital cost is annualised to a five-year period, with a fixed interest rate of 5%.

To apply the automated targeting technique for a property-based IPWI, minor modifications are needed on the earlier described concentration-based material and load cascades. In particular, the concentration levels in the cascade diagram (Figs. 1 and 4) are to be replaced by the property operator levels. Apart from conducting cascade analysis for water recovery between two wafer plants, water regeneration (for further reuse/recycle) and wastewater treatment (for final discharge) are considered simultaneously in the overall framework of the total water network [46]. Hence, new terms of regeneration and wastewater flowrate variables ($F_{wwi,k}$) are added in the revised form of Eq. (1) as shown in Eq. (1a). Since individual wastewater streams emit from each quality level, the net material flowrate at the final quality level of each network that represent the total wastewater flowrate is set to zero (Eq. (17)). Besides, the residual impurity load expressed in Eq. (2) is replaced by the residual property load ($\beta_{m,k}$), while the concentration interval ($C_m - C_{m-1}$) is replaced by operator intervals, i.e. $\Psi_m - \Psi_{m-1}$, as shown in Eq. (18).

$$\delta_{m,k} = \delta_{m-1,k} + \left(\sum_{i \in I} F_{SRi,k} + \sum_{k,k' \in K} F_{k',k}^{IMP} \right)_m - \left(\sum_{j \in J} F_{SKj,k} + \sum_{k,k' \in K} F_{k,k'}^{EXP} \right)_m - \left(\sum_{i \in I_k} F_{WWi,k} \right)_m \quad (1a)$$

$k \neq k', \forall k \in K, \forall m \in M$

$$\delta_{n-1} = 0 \quad (17)$$

$$\beta_{m,k} = \beta_{m-1,k} + \delta_{m-1,k} (\Psi_m - \Psi_{m-1}) \quad \forall m \in M, \forall k \in K \quad (18)$$

Two interception units are considered in this problem, each with different performance and unit treatment cost, as shown in Table 4. In this case, these units will perform both as water regenerator and/or as wastewater treatment unit for final discharge. Since heavy metal content is the main concern for final discharge (with a discharge limit of 2 ppm), a wastewater cascade analysis (WWCA) is next performed to determine the minimum treatment flowrate in order to comply with the discharge limit, with a generic cascade diagram shown in Fig. 7. Note that concentration levels are used here, as heavy metal content is essentially concentration-based.

To perform the WWCA, the unutilised sources will be taken from each operator level m of the reuse/recycle cascade as wastewater streams [46,60]. Hence, the identified wastewater streams from Eq. (17) are taken as sources in the wastewater cascade. Wastewater flowrate cascading is performed across all concentration levels s , similar to the earlier case on material cascading for reuse/recycle. Whenever a wastewater source i exists, a treatment flowrate, $F_{TRI,l}$ may be withdrawn for treatment unit l . Hence, this appears as sink in the wastewater cascade. Eq. (19) indicates that the net waste

Table 4
Performance and unit cost for interceptor for Example 3.

Interceptor (q/l)	Outlet concentration of heavy metal, C_D (ppm)	Resistivity, R (MΩ)	Interception cost, R_{COSTq}/T_{COSTl} (\$/t)
I	2	5	0.9
II	2	8	1.5

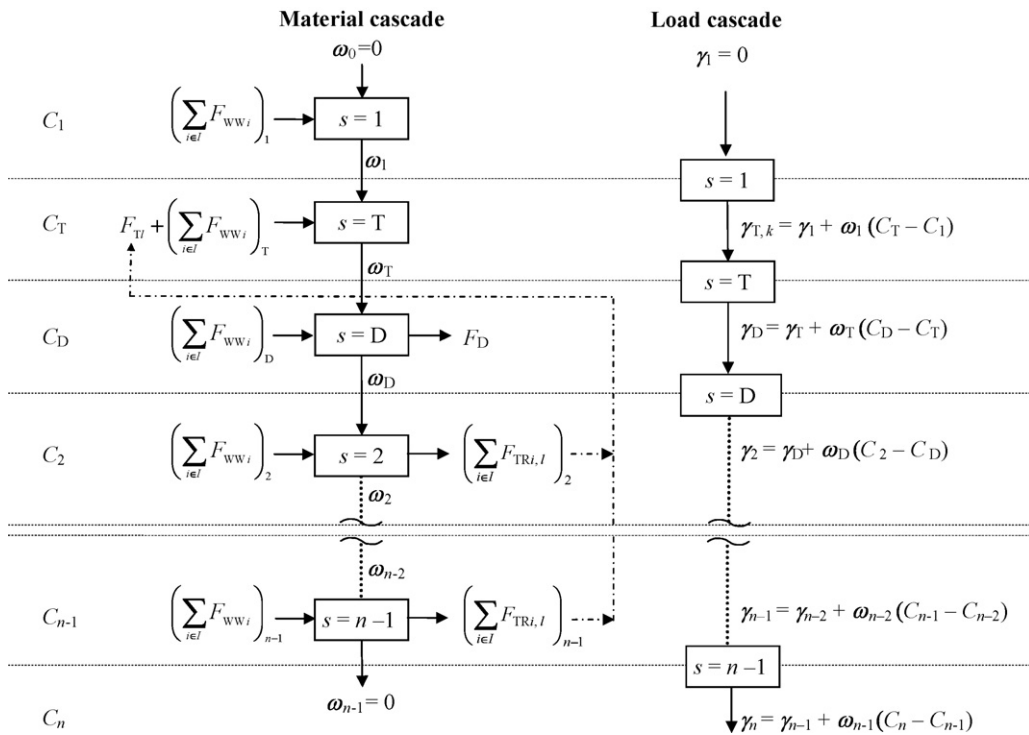

Fig. 7. Generic concentration wastewater cascade diagram for IPWI with fixed outlet property type interception unit.

Ψ_m ($M\Omega^{-1}$)	$F_{B,A}^{IMP}$	F_1^{REG}	F_2^{REG}	F_{SRi}	δ_m	F_{SKj}	F_1^R	F_2^R	$F_{A,B}^{EXP}$	β_m
					$F_{FW,A}^{IPWI} = 252.02$					
0.1					↓	700.00				11.20
					-447.98					↓
0.125	107.21	0	1170.77		↓	450.00				0
					380.00					↓
0.143					↓	500.00				6.84
					-120.00					↓
0.2	0	470.00	0		↓	350.00				0
					0.00					↓
0.333				350.00	↓		0	350.00	0	0
					0.00					↓
0.5				400.00	↓		170.00	230.00	0	0
					0.00					↓
1				250.00	↓		0	250.00	0	0
					0.00					↓
2				280.00	↓		166.35	113.65	0	0
					0.00					↓
10				300.00	↓		300.00	0	0	0
					0.00					↓
1000000										0

(a) Network A

Ψ_m ($M\Omega^{-1}$)	$F_{A,B}^{IMP}$	F_1^{REG}	F_2^{REG}	F_{SRi}	δ_m	F_{SKj}	F_1^R	F_2^R	$F_{B,A}^{EXP}$	β_m
					$F_{FW,B}^{IPWI} = 220.78$					
0.0625					↓	181.70				1.53
					39.08					↓
0.1					↓	158.99				3.00
					-119.91					↓
0.125				227.12	↓		0	0	107.21	0
					0.00					↓
0.5				227.12	↓		0	227.12	0	0
					0.00					↓
1000000										0

(b) Network B

Fig. 8. Cascade diagram for Example 3 (flowrate is given in t/h).

flowrate at levels s (ω_s), is given by the summation of the net wastewater flowrate cascaded from the earlier concentration level (ω_{s-1}) with the net flowrates at concentration level s . Since no flowrate is received at the first concentration level nor discharged from the last level, net waste flowrates at these levels are both set to zero (Eq. (20)).

$$\omega_s = \omega_{s-1} + \left(\sum_{i \in I} F_{WWi} \right)_s - \left(\sum_{l \in L} \sum_{i \in I} F_{TRi,l} \right)_s \quad \forall s \in S \quad (19)$$

$$\omega_0 = \omega_{n-1} = 0 \quad (20)$$

Since regeneration and wastewater treatment are considered simultaneously, upper bound of the interception flowrates is set to the sum of regeneration and wastewater flowrates. Hence, Eq. (7) is modified as:

$$F_{WWi} + \sum_{q \in Q} F_{i,k,q}^R \leq F_{SRi} \quad \forall i \in I \quad (7a)$$

It is worth noting that wastewater stream with either equal or lower concentration than the discharge limit will not be sent for waste treatment, since it is ‘clean’ enough to be disposed without treatment. In most cases, they will be mixed with other waste streams before being discharged to the environment [21–24]. This latter feature is well taken care off by the WWCA techniques, which is mainly based on the same framework of the automated targeting technique. Next, the total treatment flowrate for treatment unit l (F_{Tl}), given as the sum of the individual treated flowrates in these units in Eq. (21), is added as a source at the treatment outlet concentration level C_T (in order for it to mix with other source prior to discharge), as shown in Fig. 7. Finally, Eq. (22) indicates that the final wastewater flowrates, F_D is added as a sink at the discharge concentration level C_D , given as the sum of all wastewater flowrates emitted from source i .

$$F_{Tl} = \sum_{i \in I} F_{TRi,l} \quad \forall q \in Q \quad (21)$$

$$F_D = \sum_{i \in I} F_{WWi} \quad (22)$$

C_s (ppm)	F_{WWi}	ω_s	F_{TRi}	γ_s
		0.00		
		↓		0
		0.00		
$C_T = C_D = 2$	$F_{T1} = 166.35$	↓	$F_{D1} = 166.35$	0
		0.00		
4.5		↓		0
		0.00		
5	$F_{WW6} = 166.35$	↓	$F_{TR6,1} = 166.35$	0
		0.00		
10		↓		0
		0.00		
11		↓		0
		0.00		
1000000				0

Fig. 9. Wastewater cascade diagram for Example 3 (flowrate is given in t/h).

Similar to the earlier case for reuse/recycle, load cascading is also carried out for wastewater cascade in which the residual load at each level (γ_s) is calculated through Eq. (23). Eq. (24) denotes that the residue contaminant load should take a non-negative value or zero (where pinch occurs).

$$\gamma_s = \gamma_{s-1} + \omega_{s-1}(C_s - C_{s-1}) \quad \forall s \in S \quad (23)$$

$$\gamma_s \geq 0 \quad \forall s \in S \quad (24)$$

Solving Eq. (12) subjects to the constraints in Eqs. (1a), (3), (6), (17) and (18) for water recovery, Eqs. (13–16) for cross-plant piping cost, as well as Eqs. (7a), (19–24) for wastewater treatment, the minimum cost solution of \$28,695,040/y is generated. Figs. 8 and 9 show the cascade diagrams for water recovery in each network as well as the wastewater treatment section. Fig. 10 shows the network design that achieves the minimum cost target. Similar to Example 2, this network is a hybrid of direct and indirect integration schemes presented by Chew et al. [44]. The former is observed with a cross-plant pipeline of a flowrate of 107.21 t/h connecting between SK1 (Plant A) and SR7 (Plant B). The indirect scheme is also observed where Interceptor II purifies water from both Networks A and B and sends the intercepted flowrate (1170.77 t/h) for reuse/recycle in Network A. Besides, a total flowrate of 636.35 t/h from Network

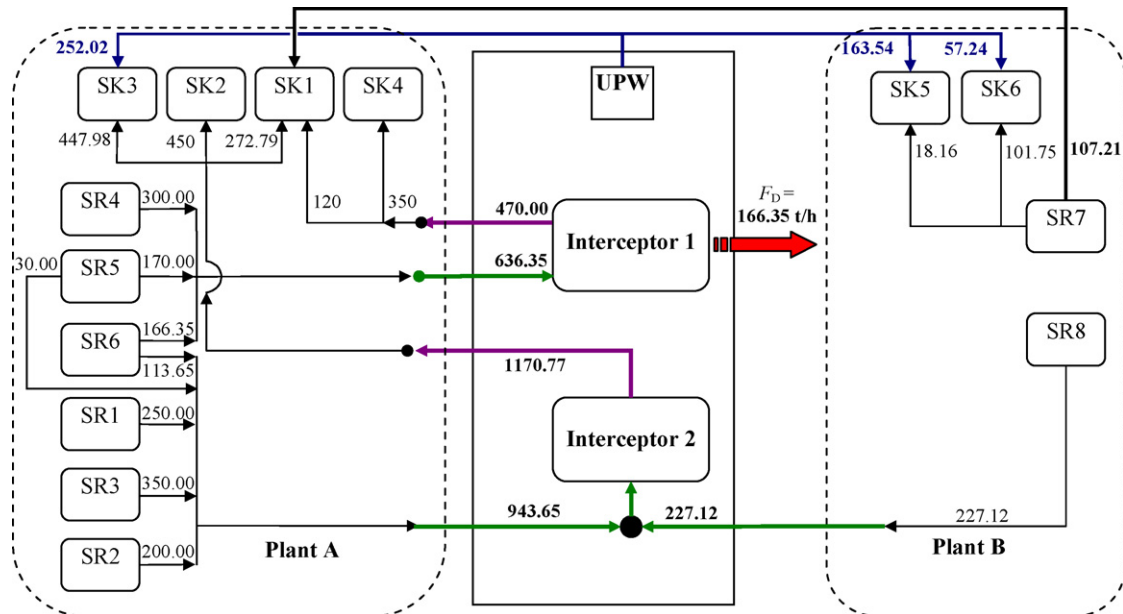

Fig. 10. Inter-plant water network design for wafer fabrication plants (flowrate is given in t/h).

A is sent for treatment in Interceptor I. Of this flowrate, a big portion (470 t/h) is sent for reuse/recycle in Network A, while the remaining (166.35 t/h) is being discharged to the environment (F_D).

9. Conclusion

This work extends the recent developed automated targeting technique for single water network into IPWI. The technique incorporates the advantages from both pinch analysis and mathematical optimisation, in which the minimum flowrate or cost targets for an IPWI problem are set prior to detailed water network design. The developed targeting technique is applicable for property-based IPWI problem, where the reuse/recycle problems are driven by properties or functionality of the process streams.

Acknowledgement

The financial support from University of Nottingham through New Researcher Fund (NRF 3822/A2RBR9) and Research Studentship is gratefully acknowledged. Funding from the Ministry of Science, Technology and Innovation (MOSTI) Malaysia through Science Fund (03-02-12-SF0018) is deeply appreciated.

References

- [1] M.W. Rosegrant, X. Cai, S.A. Cline, Global Water Outlook to 2025 – Averting an Impending Crisis. International Food Policy Research Institute, Washington (2002).
- [2] Sparks Companies Inc. Global water and food outlook (2003).
- [3] B. Bliss, The pending water crisis, Quaker Eco-Bulletin 2 (5) (2002).
- [4] Center for Strategic and International Studies, global water futures. Sandia National Laboratories (2005).
- [5] Y.P. Wang, R. Smith, Wastewater minimisation, Chem. Eng. Sci. 49 (7) (1994) 981–1006.
- [6] N. Hallale, A new graphical targeting method for water minimisation, Adv. Environ. Res. 6 (3) (2002) 377–390.
- [7] M.M. El-Halwagi, F. Gabriel, D. Harell, Rigorous graphical targeting for resource conservation via material recycle/reuse networks, Ind. Eng. Chem. Res. 42 (19) (2003) 4319–4328.
- [8] Z.A. Manan, Y.L. Tan, D.C.Y. Foo, Targeting the minimum water flowrate using water cascade analysis technique, AIChE J. 50 (12) (2004) 3169–3183.
- [9] A.M. Almutlaq, V. Kazantzi, M.M. El-Halwagi, An algebraic approach to targeting waste discharge and impure fresh usage via material recycle/reuse networks, Clean Technol. Environ. Policy 7 (4) (2005) 294–305.
- [10] R. Prakash, U.V. Shenoy, Targeting and design of water networks for fixed flow rate and fixed contaminant load operations, Chem. Eng. Sci. 60 (1) (2005) 255–268.
- [11] S. Bandyopadhyay, Source composite curve for waste reduction, Chem. Eng. J. 125 (2006) 99–110.
- [12] S. Bandyopadhyay, M.D. Ghanekar, H.K. Pillai, Process water management, Ind. Eng. Chem. Res. 45 (2006) 5287–5297.
- [13] D.C.Y. Foo, Z.A. Manan, Y.L. Tan, Use cascade analysis to optimize water networks, Chem. Eng. Prog. 102 (7) (2006) 45–52.
- [14] D.C.Y. Foo, Water cascade analysis for single and multiple impure fresh water feed, Trans. IChemE (Part A) 85 (A8) (2007) 1169–1177.
- [15] D.C.Y. Foo, Flowrate targeting for threshold problems and plant-wide integration for water network synthesis, J. Environ. Manage. 88 (2) (2008) 253–274.
- [16] W.C.J. Kuo, R. Smith, Design of water-using system involving regeneration, Trans. IChemE (Part B) 76 (1998) 94–114.
- [17] V. Agrawal, U.V. Shenoy, Unified conceptual approach to targeting and design of water and hydrogen networks, AIChE J. 52 (3) (2006) 1071–1081.
- [18] J. Bai, X. Feng, C. Deng, Graphical based optimization of single-contaminant regeneration reuse water systems, Trans. IChemE (Part A) 85 (A8) (2007) 1178–1187.
- [19] X. Feng, J. Bai, X. Zheng, On the use of graphical method to determine the targets of single-contaminant regeneration recycling water systems, Chem. Eng. Sci. 62 (2007) 2127–2138.
- [20] D.K.S. Ng, D.C.Y. Foo, Y.L. Tan, R.R. Tan, Ultimate flowrate targeting with regeneration placement, Trans. IChemE (Part A) 85 (A9) (2007) 1253–1267.
- [21] Y.P. Wang, R. Smith, Design of distributed effluent treatment systems, Chem. Eng. Sci. 49 (18) (1994) 3127–3145.
- [22] W.C.J. Kuo, R. Smith, Effluent treatment system design, Chem. Eng. Sci. 52 (23) (1997) 4273–4290.
- [23] D.K.S. Ng, D.C.Y. Foo, R.R. Tan, Targeting for total water network. Part 1. Waste stream identification, Ind. Eng. Chem. Res. 46 (2007) 9107–9113.
- [24] D.K.S. Ng, D.C.Y. Foo, R.R. Tan, Targeting for total water network. Part 2. Waste treatment targeting and interactions with water system elements, Ind. Eng. Chem. Res. 46 (2007) 9114–9125.
- [25] N. Takama, T. Kuriyama, K. Shiroko, T. Umeda, Optimal water allocation in a petroleum refinery, Comput. Chem. Eng. 4 (1980) 251–258.
- [26] A. Alva-Argáez, A. Vallianatos, A. Kokossis, A multi-contaminant transshipment model for mass exchange network and wastewater minimisation problems, Comput. Chem. Eng. 23 (1999) 1439–1453.
- [27] C.H. Huang, C.T. Chang, H.C. Ling, C.C. Chang, A mathematical programming model for water usage and treatment network design, Ind. Eng. Chem. Res. 38 (1999) 2666–2679.
- [28] M. Bagajewicz, M. Savelski, On the use of linear models for the design of water utilization systems in process plants with a single contaminant, Trans. IChemE (Part A) 79 (2001) 600–610.
- [29] R. Karuppiah, I.E. Grossmann, Global optimization of multiscenario mixed integer nonlinear programming models arising in the synthesis of integrated water networks under uncertainty, Comput. Chem. Eng. 32 (2008) 145–160.
- [30] J. Jeżowski, G. Poplewski, A. Jeżowska, Optimisation of water usage in chemical industry, Environ. Prot. Eng. 29 (1) (2003) 97–117.
- [31] V. Lavric, P. Iancu, V. Pleşu, Genetic algorithm optimisation of water consumption and wastewater network topology, J. Clean. Prod. 13 (15) (2005) 1405–1415.
- [32] S. Hul, R.R. Tan, J. Auresenia, T. Fuchino, D.C.Y. Foo, Synthesis of near-optimal topologically-constrained property-based water network using swarm intelligence, Clean Technol. Environ. Policy 9 (1) (2007) 27–36.
- [33] S. Hul, R.R. Tan, J. Auresenia, T. Fuchino, D.C.Y. Foo, Water network synthesis using mutation-enhanced PSO, Trans. IChemE (part B) 85 (B6) (2007) 507–514.
- [34] Y. Luo, X. Yuan, Y. Liu, An improved PSO algorithm for solving non-convex NLP/MINLP problems with equality constraints, Comput. Chem. Eng. 31 (2007) 153–162.
- [35] R.R. Tan, D.C.Y. Foo, Z.A. Manan, Assessing the sensitivity of water networks to noisy mass loads using Monte Carlo simulation, Comput. Chem. Eng. 31 (10) (2007) 1355–1363.
- [36] D.K.S. Ng, D.C.Y. Foo, R.R. Tan, Automated targeting technique for resource conservation networks, Asia Water 2008 Conference, Malaysia.
- [37] D.K.S. Ng, D.C.Y. Foo, R.R. Tan, C.H. Pau, Y.L. Tan, Automated targeting for conventional and bilateral property-based resource conservation network, Chem. Eng. J. 149 (2009) 87–101.
- [38] S.G. Olesen, G.T. Polley, Dealing with plant geography and piping constraints in water network design, Trans. IChemE (Part B) 74 (1996) 273–276.
- [39] D. Spriggs, E. Lowe, J. Watz, M.M. El-Halwagi, E.M. Lovelady, Design and development of eco-industrial parks. AIChE Spring Meeting, New Orleans (2004).
- [40] I.M.L. Chew, D.C.Y. Foo, D.K.S. Ng, Targeting for plant-wide water integration. Joint Symposium for Chemical and Metallurgical Engineering, Pretoria, South Africa (2007).
- [41] E.M. Lovelady, M.M. El-Halwagi, G.A. Krishnagopalan, An integrated approach to the optimisation of water usage and discharge in pulp and paper plants, Int. J. Environ. Pollut. 29 (1–3) (2007) 274–307.
- [42] Z.W. Liao, J.T. Wu, B.B. Jiang, J.D. Wang, Y.R. Yang, Design methodology for flexible multiple plant water networks, Ind. Eng. Chem. Res. 46 (2007) 4954–4963.
- [43] E.M. Lovelady, M.M. El-Halwagi, Design and integration of eco-industrial parks for managing water resources, Environ. Prog. Sustain. Energy 28 (2) (2009) 265–272.
- [44] I.M.L. Chew, D.K.S. Ng, D.C.Y. Foo, R.R. Tan, T. Majozi, J. Gouws, Synthesis of direct and indirect interplant water network, Ind. Eng. Chem. Res. 47 (23) (2008) 9485–9496.
- [45] M.M. El-Halwagi, V. Manousiouthakis, Automatic synthesis of mass-exchange networks with single component targets, Chem. Eng. Sci. 9 (1990) 2813–2831.
- [46] D.K.S. Ng, D.C.Y. Foo, R.R. Tan, Automated targeting technique for total water network. Regional Symposium on Chemical Engineering and Symposium of Malaysian Chemical Engineering (RSCE-SOMChE), Malaysia (2008).
- [47] D.K.S. Ng, Synthesis of resource conservation network with interception placement. PhD Thesis, University of Nottingham (2008).
- [48] M.D. Shelley, M.M. El-Halwagi, Component-less design of recovery and allocation systems: a functionality-based clustering approach, Comput. Chem. Eng. 24 (9–10) (2000) 2081–2091.
- [49] M.M. El-Halwagi, I.M. Glasgow, X. Qin, M.R. Eden, Property integration: componentless design techniques and visualization tools, AIChE J. 50 (8) (2004) 1854–1869.
- [50] X. Qin, F. Gabriel, D. Harell, M.M. El-Halwagi, Algebraic techniques for property integration via componentless design, Ind. Eng. Chem. Res. 43 (14) (2004) 3792–3798.
- [51] V. Kazantzi, M.M. El-Halwagi, Targeting material reuse via property integration, Chem. Eng. Prog. 101 (8) (2005) 28–37.
- [52] D.C.Y. Foo, V. Kazantzi, M.M. El-Halwagi, Z.A. Manan, Surplus diagram and cascade analysis technique for targeting property-based material reuse network, Chem. Eng. Sci. 61 (8) (2006) 2626–2642.
- [53] D. Grooms, V. Kazantzi, M.M. El-Halwagi, Optimal synthesis and scheduling of hybrid dynamic/steady-state property integration networks, Comput. Chem. Eng. 29 (11–12) (2005) 2318–2325.
- [54] D.K.S. Ng, D.C.Y. Foo, A. Rabie, M.M. El-Halwagi, Simultaneous synthesis of property-based water reuse/recycle and interception networks for batch processes, AIChE J. 54 (10) (2008) 2624–2632.
- [55] S. Bandyopadhyay, C.C. Cormos, Water management in process industries incorporating regeneration and recycle through a single treatment unit, Ind. Eng. Chem. Res. 47 (4) (2008) 1111–1119.

- [56] E.M. Lovelady, M.M. El-Halwagi, I.M.L. Chew, D.K.S. Ng, D.C.Y. Foo, R.R. Tan, 7th International Conference on Foundations of Computer-Aided Process Design (FOCAPD) 2009, Colorado, 7–12th June (2009).
- [57] M.M. El-Halwagi, *Process Integration*, Elsevier, Amsterdam, 2006.
- [58] J.K. Kim, R. Smith, Automated design of discontinuous water systems, *Trans. IChemE, Part B* 82 (B3) (2004) 238–248.
- [59] R. Smith, *Chemical Process Design and Integration*, John Wiley & Sons, New York, 2005.
- [60] D.K.S. Ng, D.C.Y. Foo, R.R. Tan, M.M. El-Halwagi, Automated targeting for total property-based network. 19th European Symposium on Computer Aided Process Engineering – ESCAPE19, Poland (2009).